

ETW Series

Demagnetisation Unit with Trolley

For the demagnetisation of larger and heavier workpieces, which cannot be passed through a demagnetisation spool manually, we recommend the use of an ETW demagnetisation unit with trolley.

The workpieces for demagnetisation are placed onto the trolley on the shorter outrigger side, and manually pushed through the tunnel towards the longer side. The demagnetisation spools generate a strong magnetic field, which requires a specific safety distance in accordance with BGV B11.



PRODUCT PROPERTIES AND PART NUMBERS

	ETW 350	ETW 550
Part number	102355	102555
Field strength	10 kA/m	6.2 kA/m
Mains connection	400 V	400 V
Current consumption	8.5 I (A)	12 I (A)
Power consumption	3.4 kVA	4.8 kVA
Frequency	50 Hz	50 Hz
Measurement A	480 mm	680 mm
Measurement B	350 mm	550 mm
Measurement C	260 mm	460 mm
Measurement D	475 mm	695 mm
Measurement E	1190 mm	1410 mm
Measurement F	325 mm	325 mm

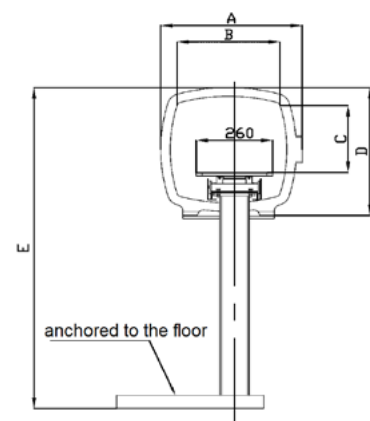
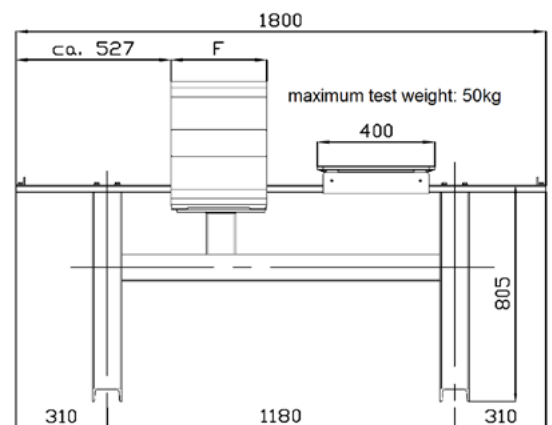

ETW Series

Demagnetisation is an important component of electromagnetic crack testing. Residual magnetism in test samples is an issue for many users and the industry demands increasingly better demagnetisation values.

Where workpieces are subjected to a magnetic field due to a magnetisation process - as part of a testing method, processing, or from magnetic lifting equipment - a residual magnetic field will remain in the component after the field-generating source has been disabled (remanence), which must be neutralised. Eliminating this magnetic residue will help avoid negative effects during later processing or when using the workpieces.

The demagnetisation of AC-supplied spools that have a frequency of 50 Hz, occurs by way of the slow retraction of the test object from the field-filled space of the demagnetisation spool, in direction of the spool axis.

At the start of demagnetisation, the field strength must be at least equal to the field strength of the magnetisation. Similarly, the entire area for demagnetisation must be captured. While a field saturation depth of approx. 2mm can be expected in magnetic particle testing with alternating magnetic field, for components that were manipulated with lifting equipment, the entire cross section of the test object must be covered. In the latter case, demagnetisation is achieved with an increased field saturation depth, whereby the field intensity is decreased with low-frequency AC or reversing DC current.

The most important basis for achieving good demagnetisation results is:

- for parts that were **AC**-magnetised: demagnetisation at 50 or 60 Hz AC or low-frequency AC.
- for parts that were **DC**-magnetised: demagnetisation with low-frequency AC only (e.g. 16 2/3 Hz).

USER RECOMMENDATIONS

NDT Method	Magnetic Particle Testing
Accessories	Low-frequency generator 16 2/3 Hz: AC 230V / 50Hz; Out AC 230V (part number 10700) AC 400V / 50Hz; Out AC 400V (part number 104710)